

GRID 2102 PORTABLE DISKETTE DRIVE OWNER'S MANUAL

7 JULY 1983

Order Number 2102-40

COPYRIGHT © 1983 GRiD Systems Corporation
2535 Garcia Avenue
Mountain View, CA 94043
(415) 961-4800

Manual Name : 2102 Portable Diskette Drive Owner's Manual
Order Number 2102-40
Issue date: July 7, 1983

No part of this publication may be reproduced, stored in a retrieval system, or transmitted, in any form or by any means, electronic, mechanical, photocopy, recording, or otherwise, without the prior written permission of GRiD Systems Corporation.

The information in this document is subject to change without notice.

NEITHER GRiD SYSTEMS CORPORATION NOR THIS DOCUMENT MAKES ANY EXPRESSED OR IMPLIED WARRANTY, INCLUDING, BUT NOT LIMITED TO THE IMPLIED WARRANTIES OF MERCHANTABILITY, QUALITY, OR FITNESS FOR A PARTICULAR PURPOSE. GRiD Systems Corporation makes no representation as to the accuracy or adequacy of this document. GRiD Systems Corporation has no obligation to update or keep current the information contained in this document.

GRiD System Corporation's software products are copyrighted by and shall remain the property of GRiD Systems Corporation.

The following are trademarks of GRiD Systems Corporation: GRiD, NAVIGATOR, COMPASS CENTRAL, COMPASS COMPUTER, and LEVERAGED LEARNING.

FLOPPY DISKETTE RECOMMENDATION

For proper operation, GRiD Systems Corporation recommends that users of the GRiD 2102 portable diskette drive purchase and use only the following diskette media. This media has reinforced diskette hubs.

<u>Manufacturer</u>	<u>Model</u>
Dysan	104/2D #802060

GRiD further recommends that users with diskettes which do not have reinforced diskette hubs purchase a hub reinforcing kit.

TABLE OF CONTENTS

CHAPTER 1. PHYSICAL DESCRIPTION

The Front View	1-1
The In-Use Light	1-2
The Diskette Drive	1-2
The Power Switch	1-2
The Rear View	1-2
The Power Connector	1-3
The Fuse	1-3
The Line Voltage Switch	1-3
The GPIB Connector	1-4
The Expansion Connector	1-4
The Address Switches	1-4

CHAPTER 2. SET UP AND OPERATION

Connecting the Portable Diskette Drive and the Computer	2-1
The GPIB Connector	2-2
Operating the Portable Diskette Drive	2-3
Formatting Floppy Diskettes	2-4
Write-Protecting Floppy Diskettes	2-4
Taking Care of Floppy Diskettes	2-4
Device Precedence	2-5
Returning Control to the Bubble	2-6
Backing Up Files on Floppy Diskette	2-6

LIST OF FIGURES

Figure 1-1. The Disk Unit: Front View	1-1
Figure 1-2. The Disk Unit: Rear View	1-3
Figure 1-3. The Line Voltage Switch	1-4

Figure 2-1.	A Typical System Configuration Using GPIB Cables . . .	2-2
Figure 2-2.	Two Connected GPIB Cables	2-2
Figure 2-3.	Inserting a Diskette into the Floppy Drive	2-4

CHAPTER 1: PHYSICAL DESCRIPTION

The 2102 Portable Diskette Drive is a floppy diskette drive in a compact package approximately two-thirds the size of the Compass Computer. The 2102 accepts double-sided, double-density, 5-1/4 inch floppy diskettes.

THE FRONT VIEW

The front view of the disk unit is shown in Figure 1-1 and is described in the paragraphs that follow.

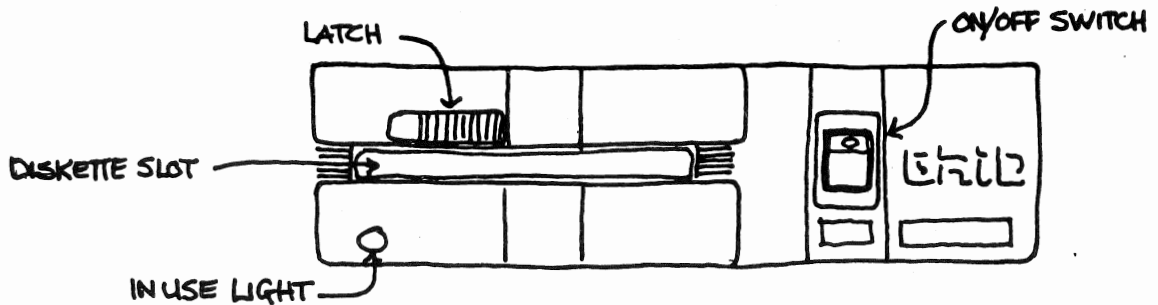

Figure 1-1. The Portable Diskette Drive: Front View

The In-Use Light

The In-Use light located below and to the left of the floppy disk opening shows you when the floppy disk is being accessed.

The Floppy Diskette Drive

The 5 1/4" floppy diskette drive occupies the left portion of the disk unit. The drive only spins the diskette when instructed to read or write data. When the floppy diskette is being accessed to read or write data, the In-Use light is illuminated, and the drive emits clicking and other sounds.

Floppy diskettes, or "floppies," are flexible plastic disks that have been coated with a magnetic material (much like the coating on audio recording tape). The diskette spins inside a protective plastic jacket.

One floppy diskette stores up to 360 thousand characters of data. Floppy diskettes can be (and should be) removed from the drive when not being used. By changing diskettes you can store and retrieve information for many different applications.

The Power Switch

When the Power switch is in the off position, you can see a little red circle on its top. Pressing in the upper portion of the switch will turn the unit on. Pressing the lower portion of the switch will turn the unit off.

CAUTION: Never turn either the disk unit or the computer off when the In-Use light is lit. The in-use display means that file access may be taking place. Turning either the disk or computer off could destroy files. Additionally, never turn the disk unit on or off while there is a floppy diskette inserted in the disk unit.

THE REAR VIEW

Figure 1-2 shows the rear view of the disk unit.

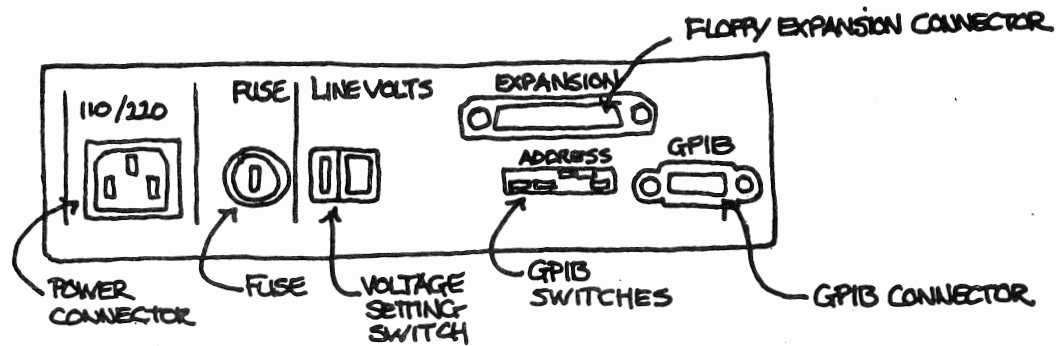

Figure 1-2. The Portable Diskette Drive: Rear View

The Power Connector

The three-prong male connector provides a ground plug. The male end of the power cord supplied with the disk unit also has three prongs and should be plugged into an outlet that accepts this type of plug. If the power outlet does not provide proper grounding, read and write errors may occur.

The Fuse

The fuse protects the drive unit from out of range electrical input. The fuse that comes with the unit is a 1 ampere, slow-blow fuse mounted in a gray holder/cover for the 110 VAC Line Voltage setting. (A description of the Line Voltage switch is given in the paragraph that follows.)

If you switch to the 220 VAC setting, be sure to exchange the 1 ampere fuse for a 500 milliampere slow-blow type fuse which is mounted in a black holder/cover. You can gain access to the fuse by turning the fuse cover in a counter-clockwise direction. The appropriate fuse and a power cord that can be used in European countries can be obtained from GRiD. The order number for this European packet is 31027-00.

The Line Voltage Switch

The Line Voltage switch lets you switch between 110 volts AC and 220 volts AC. As shown in Figure 1-3 below, the switch is set to its leftmost position for 110 volts and to the right for 220 volts. **WARNING:** Always make sure this switch is on its proper setting before plugging the power cord into an electrical outlet. An

incorrect voltage setting could damage the disk unit when power is applied. Also ensure that you have the appropriate fuse installed for the line voltage you've selected.

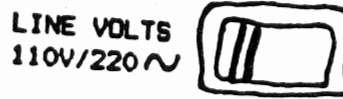

Figure 1-3. The Line Voltage Switch (shown set for 110V)

The GPIB Connector

Use this connector to connect the disk unit to the computer and to other peripherals. Chapter 2 describes the GPIB connector in detail and shows you how to connect the disk system with the computer.

The Expansion Connector

Use this connector to connect the 2102 Portable Diskette Drive to a 'slave' floppy drive -- the 2103 Portable Diskette Drive. The 2102 provides power, data, and control signals to a 'slave' drive via the expansion connector.

The Address Switches

These switches set up an address that the computer uses to direct data to and from the disk unit. The switches should be set with switches 2 and 3 on (up) and the others off (down) as shown below:

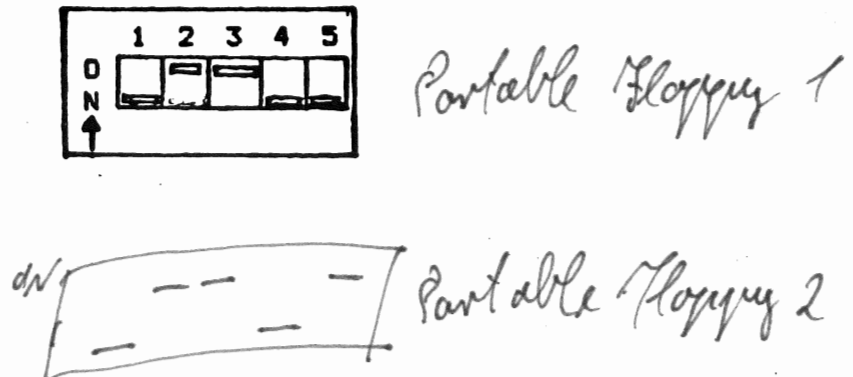

CHAPTER 2: SET UP AND OPERATION

This chapter shows you how to set up your Portable Diskette Drive and how to use it.

CONNECTING THE PORTABLE DISKETTE DRIVE AND THE COMPUTER

To set up the portable diskette drive, you need the following items:

- o A Compass Computer
- o The 2102 Portable Diskette Drive
- o A power cord
- o A GPIB cable

The GPIB Connector

Cables that attach to each device's GPIB connector link most GRiD peripherals. GPIB conventions let you hook any device to any other device. For example, Figure 2-1 shows a disk, then a printer, and finally a plotter connected to the computer. A device's position relative to the computer doesn't matter. You could just as easily put the plotter first, then the disk, followed by the printer.

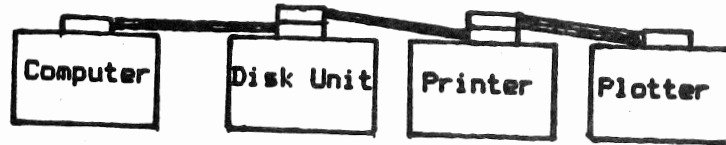

Figure 2-1. A Typical System Configuration Using GPIB Cables.

When attaching the GPIB cables, follow the example shown in Figure 2-1; attach only one connector to the computer and no more than two on any peripheral. See Figure 2-2 below.

The GPIB connector has a trapazoidal "D" shape. The broader part of the connector is on top. Take advantage of the connector screws; tighten them down to ensure uncompromised data transmission. To tighten, use your fingers; do not use tools. Tools may overtighten and cause damage. Avoid applying heavy pressure to the connector itself.

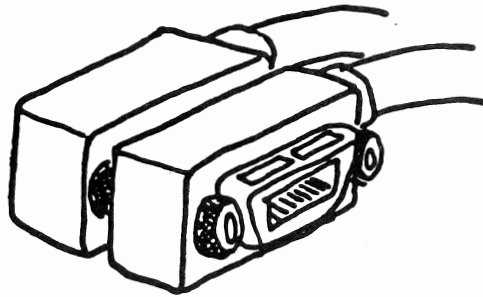

Figure 2-2. Two Connected GPIB Cables

▶ CONNECTING THE PORTABLE DISKETTE DRIVE TO THE COMPUTER

1. Make sure that the computer, the portable diskette drive, and other peripherals are turned off.
2. Connect a GPIB cable to the connector on the back of the portable diskette drive (see GPIB instructions above).
3. Connect the other end of the cable onto the back of the computer. If you have already connected another device to the computer, connect the portable diskette drive to another device's GPIB connector.
4. Connect the female end of the power cord to the back of the portable diskette drive and the male end of the cord to an appropriate power source. Ensure that the Line Voltage switch on the back of the portable diskette drive is set to the correct position.
5. Make sure everything is plugged in, then turn the portable diskette drive (and any other peripherals in the system) on and then turn the computer on.

OPERATING THE PORTABLE DISKETTE DRIVE

Operation of the portable diskette drive simply consists of following a simple procedure for inserting and removing diskettes from the drive. This section also describes other procedures to follow regarding the floppy diskettes themselves: formatting diskettes, write-protecting the diskettes, and general guidelines for taking care of your diskettes.

To insert a floppy diskette into the disk unit, rotate the latch mechanism on the front of floppy drive opening to the horizontal position, then slide the diskette into the opening. See Figure 2-3, "Inserting a Diskette into the Portable Diskette Drive." Be sure the diskette label enters last and faces upward. The square notch should be on the left side of the diskette. Sometimes a "write-protect" tab will cover this notch. ("Write protecting" a diskette is discussed later in this section.)

Push the diskette in until you hear a 'click' indicating that it is all the way in. Then rotate the latch mechanism clockwise to the vertical position until it 'clicks'.

WARNING: Always make sure that the disk unit is turned on before you insert a floppy diskette. If you turn power on or off while a floppy is in the disk unit, data on the diskette may be destroyed.

To remove a diskette from the disk unit, simply rotate the latch

counterclockwise to the horizontal position. The diskette will automatically be ejected from the drive.

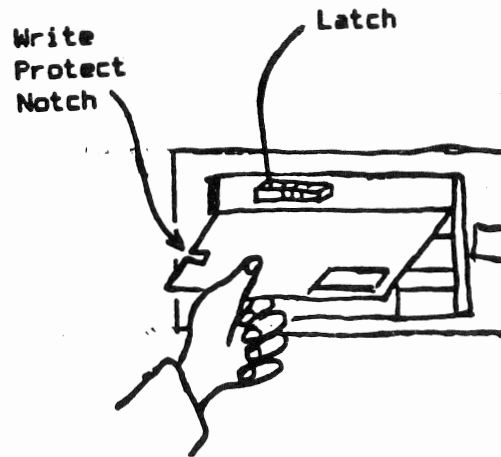

Figure 2-3. Inserting a Diskette into the Portable Diskette Drive

Formatting Floppy Diskettes

The disk unit expects floppy diskettes to have their data organized in a very particular format. To ensure that a new diskette can be read and written by the disk unit, you must format each diskette before the floppy drive can use it. To format a diskette you must run the Initialize Media program as described in the Compass Computer System Reference Manual.

Write-Protecting Floppy Diskettes

If you have data stored on a diskette that you want to protect from being inadvertently being written over, you can put a "write-protect" tab over the write-protect notch on the edge of diskette. (See Figure 2-3 for the location of the write-protect notch.) Typically, a sheet of self adhesive "tabs" for covering this notch are included in the box in which your diskettes are held.

Taking Care of Floppy Diskettes

To prevent destroying data on your floppy diskettes, treat them with care -- as though they were fine phonograph recordings. Always keep the following tips in mind:

- o Do not touch the surface of the diskettes through the openings in their jackets. An invisible scratch on the surface of the diskette, or even a fingerprint can cause

errors.

- o Always return a diskette to its protective envelope after removing it from the drive. You should store diskettes in protective casings -- such as diskette boxes or albums -- and it is best to store them vertically.
- o Keep them away from magnetic fields, such as those generated by magnetic office items (paper clip dispensers, magnetic paper holders, etc.) or electronic instruments (TV's, speakers, and even CRT's).
- o Do not expose diskettes to direct sunlight or extremes of temperature. For optimum long-term storage, keep diskettes at a temperature between 60 and 70 degrees Fahrenheit (15 to 20 degrees Celsius). The maximum permissible temperature range at which diskettes should be stored is from 50 F-125 F (10 C-52 C).
- o Do not bend, fold, staple, or otherwise mistreat a diskette. Never write on a diskette label with any implement other than a felt tip pen and then, only with a gentle pressure.

DEVICE PRECEDENCE

The computer chooses the device (Bubble, Hard Disk, Floppy Disk, or Portable Floppy) from which it loads the operating system software according to which device has precedence. (The operating system is a group of programs that give the computer its basic capabilities, such as running application programs and communicating with peripherals.)

The order of precedence is as follows. The computer looks first to the bubble memory for the operating system software. If the software does not exist on the bubble, the computer turns to the 2101 hard disk (if present) and the 2101 floppy diskette. Finally, if there is no 2101 Disk Unit connected to the system, or if its hard disk or floppy drive don't hold the needed program, the computer checks the portable diskette drive.

It is possible to override this automatic precedence. This becomes necessary only in the case of certain maintenance activities. The rest of this section shows you how to load the operating system from the hard disk and the floppy and how to return precedence to the bubble.

▶ STARTING FROM A FLOPPY DISKETTE

1. Turn the computer off.
2. Turn the disk unit on.
3. Insert a system diskette (one containing a copy of the operating system) in the portable diskette drive.
4. Turn the computer on.
5. Immediately (within approximately 2 seconds) press the "F" key on the computer keyboard. The floppy disk will activate and the In Use indicator will be lit. You can now release the "F" key. The computer will load the operating system from the floppy disk. If you inserted a diskette that does not have the operating system software, the message "Cannot boot: Storage medium error" will be displayed.

Returning Control to the Bubble

To return control to the bubble, simply select Bubble as the device on the File Form. Additionally, if you turn the computer off and then back on, control will automatically be returned to the bubble.

BACKING UP FILES ON FLOPPY DISKETTE

We cannot overemphasize the importance of making copies of important files. This process of "backing up" files protects your work from accidentally writing one file over another, power failures, media failures, etc. Make backups of files daily, if not more often. For a discussion of how to back up your files by duplicating them to floppy diskettes, refer to the Compass Computer System Reference Manual.