

# Management Tools Workshop Module 1

1. Overview of Navigator system.



2. GRiDWRITE text editor.

3. Subject and title commands.

4. GRiDPLAN worksheet editor.

# Getting Started

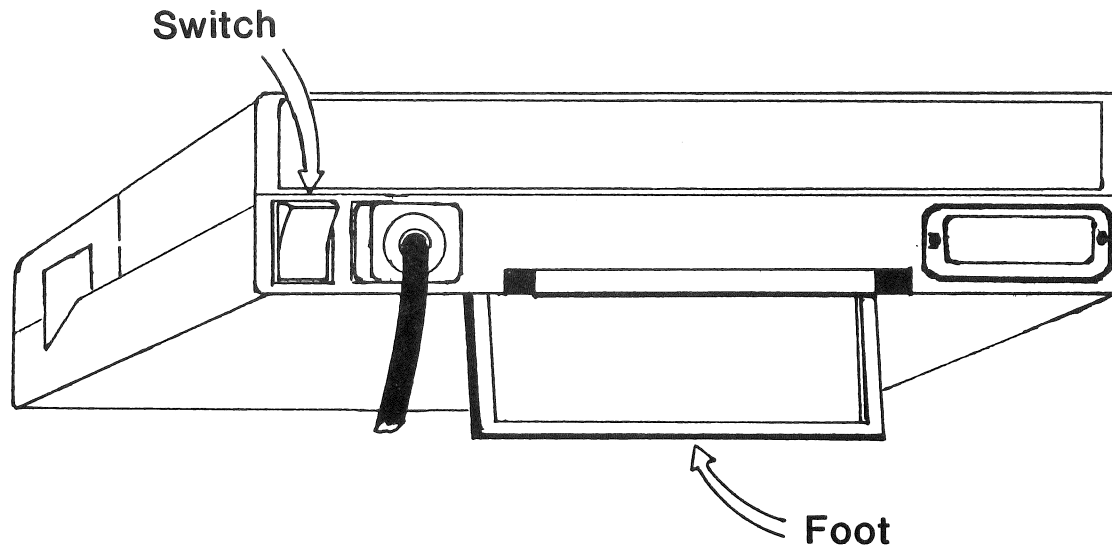

1

Lower foot.

2

Turn power on.

# Subjects

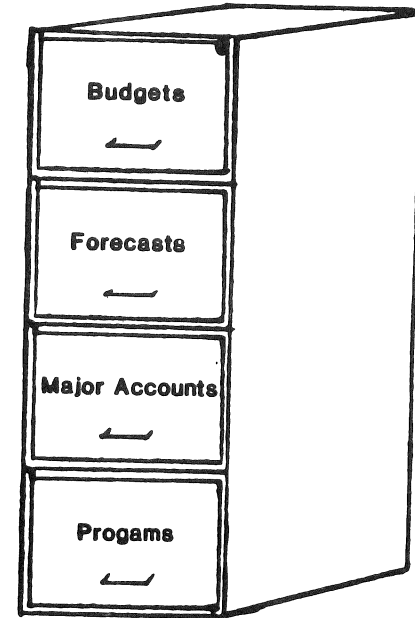
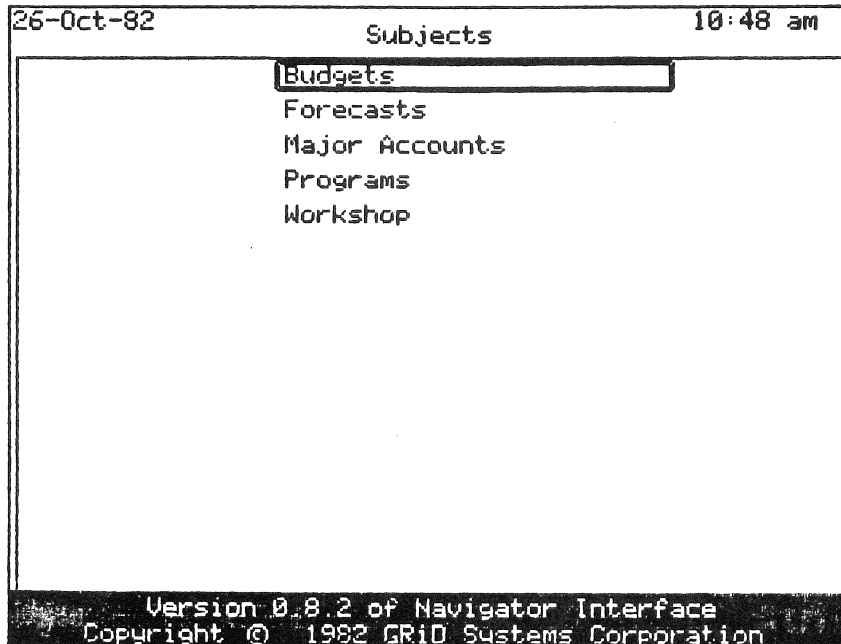

- Subjects are like file drawers.

Each contains a set of files.

# Selecting a Subject

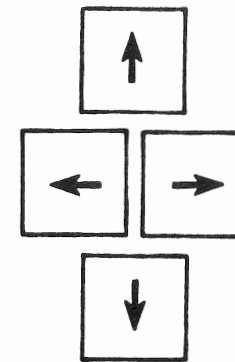
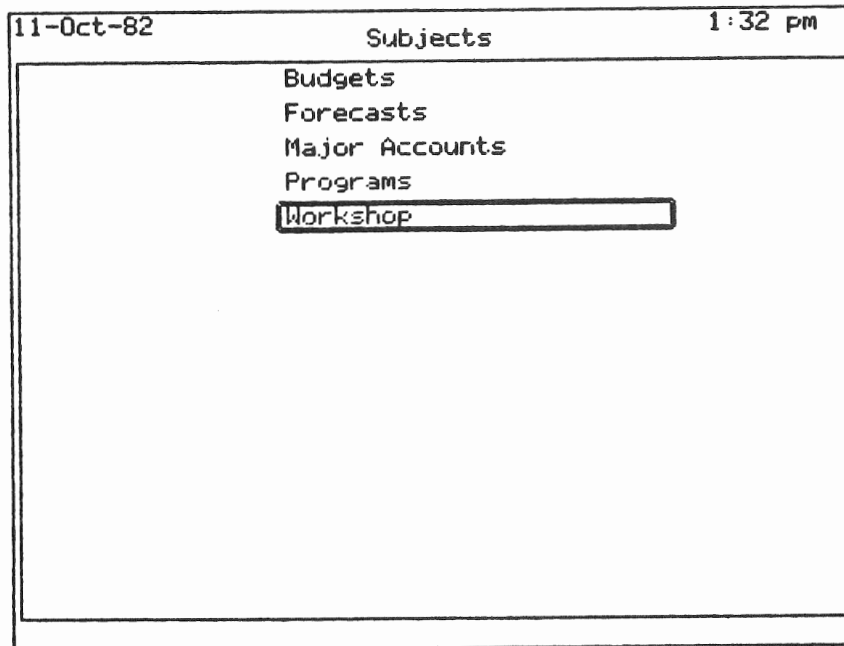

arrow keys

▶ Press  to outline subject "Workshop".  

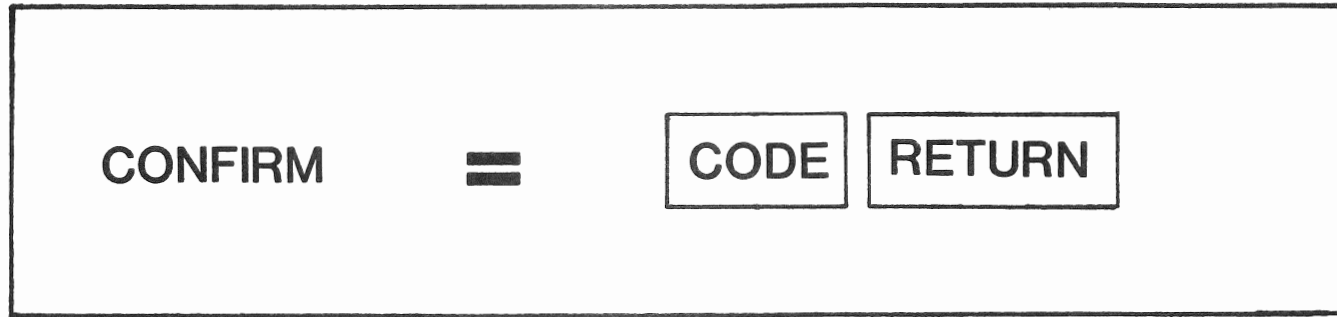

# CONFIRM



CONFIRM

# Titles

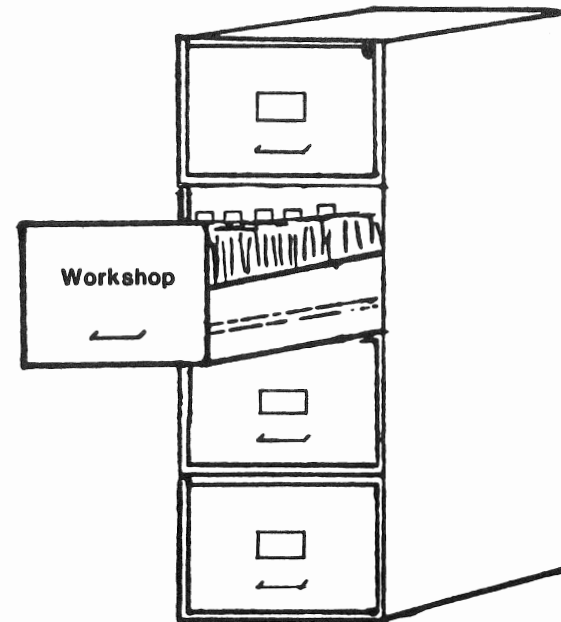
11-Oct-82		3:06 pm	
Workshop			
Titles	Kind	Medium	
backup	Worksheet	BubbleMemory	
Employee histories	Database	BubbleMemory	
Furniture Div: Forecast	Worksheet	BubbleMemory	
Memo	Text	BubbleMemory	
Trip Report	Text	BubbleMemory	



- Each file has a
  - Subject
  - Title
  - Kind
  - Medium

# Selecting a Title

11-Oct-82	Workshop		3:11 pm
Titles	Kind	Medium	
backup	Worksheet	BubbleMemory	
Employee histories	Database	BubbleMemory	
Furniture Div: Forecast	Worksheet	BubbleMemory	
Memo	Text	BubbleMemory	
<u>Trip Report</u>	Text	BubbleMemory	

1

Press

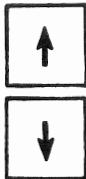

keys to outline title

2

CONFIRM

# File Trip Report

cursor



TRIP REPORT SUMMARY

9/15/82

Submitted by: Tom Fanauff CCD

Automotive sails division: District 4

Central Dealer: J. Chase

This memo highly recommends the redistribution of sails allotments for dealers in district 4 of the automotive sails division based on the projected sails for the first four months of 1983. (See exhibit A)

A complete trip report will be distributed by 9/29/82, prior to the regional review meeting in Detroit.

My decision to recommend new sails allotments for this district is supported by the following:

Version 0.4.12 of GRIDWRITE

Copyright © 1982 GRID Systems Corporation

# Scrolling

TRIP REPORT SUMMARY 9/15/82

Submitted by: Tom Faneuff CCD

Automotive sails division: District 4

Central Dealer: J. Chase

This memo highly recommends the redistribution of sails allotments for dealers in district 4 of the automotive sails division based on the projected sails for the first four months of 1983. (See exhibit A)

A complete trip report will be distributed by 9/29/82, prior to the regional review meeting in Detroit.

My decision to recommend new sails allotments for this district is supported by the following 4 points.



1) John Chase, proprietor of Sleazy Wheels Unlimited (213 E. Hummel Road) has consistently overestimated his sails projections for the last five years by an average of 22%. This is considerably out of line with the projections of the other district centers.

2) Using growth rates of 10% a month for vans, 20% a month for sedans, and 15% a month for used cars (10% above guidelines in each case) my projections show total sails revenue at only \$405.90K in April.

3) The recently announced move of SMALL TIME RENTAL CAR CO. will significantly reduce fleet sails.

4) John Chase insulted my mother at the company picnic last September.

Please respond to my suggestion by Wednesday morning.



Press



keys to view entire file.

# Exercise



Write the letter of each keystroke next to the corresponding cursor movement.

	KEYSTROKE	CURSOR MOVEMENT
A.		___ ONE WORD RIGHT
B.		___ ONE WORD LEFT
C.		___ ONE LINE UP
D.		___ ONE LINE DOWN
E.	CODE	___ LEFT END OF LINE
F.	CODE	___ RIGHT END OF LINE
G.	CODE	___ ONE CHARACTER RIGHT
H.	CODE	___ ONE CHARACTER LEFT
I.	CODE SHIFT	___ BEGINNING OF FILE
J.	CODE SHIFT	___ END OF FILE
K.	CODE SHIFT	___ TOP OF SCREEN
L.	CODE SHIFT	___ BOTTOM OF SCREEN

# Basic Editing

TRIP REPORT SUMMARY

9/15/82

Submitted by: Tom Faneuff CCD

Automotive sails division: District 4

Central Dealer: J. Chase

Region  
^

This memo highly recommends the redistribution of sails allotments for dealers in district 4 of the automotive sails division based on the projected sails for the first four months of 1983. (See exhibit A)

Contributed by

- You can insert and erase quickly

# Inserting Text

TRIP REPORT SUMMARY 9/15/82

Submitted by: Tom Faneuff CCD

Automotive sails division: District 4

Central Dealer: J. Chase

This memo highly recommends the redistribution of sails allotments for dealers in district 4 of the automotive sails division based on the projected sails for the first four months of 1983. (See exhibit A)

A complete trip report will be distributed by 9/29/82, prior to the regional review meeting in Detroit.

My decision to recommend new sails allotments for this district is supported by the following 4 points.

**1** Place cursor where you are going to insert text.

**2** Type "Region"

# Erasing Text

TRIP REPORT SUMMARY

9/15/82

Submitted by: Tom Faneuff CCD

Automotive sails division: District 4

Central Region Dealer: J. Chase

This memo highly recommends the redistribution of sails allotments for dealers in district 4 of the automotive sails division based on the projected sails for the first four months of 1983. (See exhibit A)

A complete trip report will be distributed by 9/29/82, prior to the regional review meeting in Detroit.

My decision to recommend new sails allotments for this district is supported by the following 4 points.



Press

**BACK  
SPACE**

to erase one character left of the cursor.



Press

**CODE**

**BACK  
SPACE**

to erase one word.

# Upper Case Lock

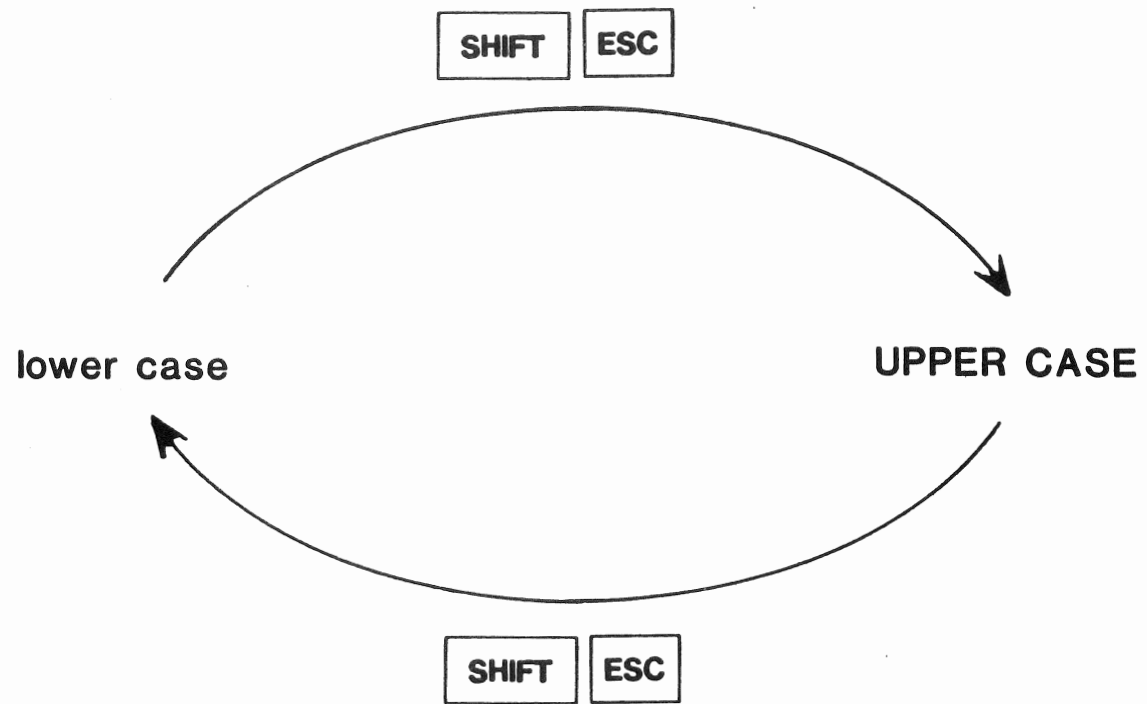

# GRiDWRITE Command Menu

```
TRIP REPORT SUMMARY                      9/15/82
Submitted by: Tom Faneuff  CCD
Automotive sails division: District 4

CODE-D Duplicate
CODE-E Erase
CODE-F Find
CODE-J Jump
CODE-M Move
CODE-O Options
CODE-Q Quit
CODE-S Substitute
CODE-T Transfer
CODE-U Usage
CODE-ESC Cancel

Commands: Select item
Version 0.4.12 of GRiDWRITE
```

1

Press **CODE** **?** to display command menu.

2

Press **ESC** to remove menu.

# Erase Command

TRIP REPORT SUMMARY

9/15/82

Submitted by: Tom Faneuff CCD

Automotive sails division: District 4

Central Region Dealer: J. Chase

This memo recommends the redistribution of sails allotments for dealers in district 4 of the automotive sails division based on the projected sails for the first four months of 1983. (See exhibit A)

A complete trip report will be distributed by 9/29/82, prior to the regional review meeting in Detroit.

My decision to recommend new sails allotments for this district is supported by the following 4

- The Erase command quickly erases any size block of text.

# Erase Command

TRIP REPORT SUMMARY	9/15/82
Submitted by: Tom Faneuff CCD	
Automotive sails division: District 4	
Central Region Dealer: J. Chase	
This memo recommends the redistribution of sails allotments for dealers in district 4 of the automotive sails division based on the projected sails for the first four months of 1983. (See exhibit A)	
A complete trip report will be distributed by 9/29/82, prior to the regional review meeting in Detroit.	
My decision to recommend new sails allotments for this district is supported by the following 4	
Erase: Make a selection	

1

Place cursor at beginning of text to be erased.

2

Press   to start erase command.

# Erase Command

```
TRIP REPORT SUMMARY 9/15/82
Submitted by: Tom Faneuff  CCD
Automotive sails division: District 4
Central Region Dealer: J. Chase

This memo recommends the redistribution of
sails allotments for dealers in district 4 of the
automotive sails division based on the projected
sails for the first four months of 1983. (See
exhibit A)

A complete trip report will be distributed by
9/29/82 prior to the regional review meeting in
Detroit.

My decision to recommend new sails allotments
for this district is supported by the following 4

Erase: Make a selection
```

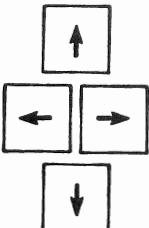
3 Press  keys to make a selection.

4 CONFIRM

*Fischer*  
**Substitute Command**

TRIP REPORT SUMMARY

9/15/82

Submitted by: Tom Faneuff CCD

Automotive **sails** division: District 4

Central Region Dealer: J. Chase

**sails** This memo recommends the redistribution of  
sails allotments for dealers in district 4 of the  
automotive **sails** division based on the projected  
sails for the first four months of 1983. (See  
exhibit A)

My decision to  
for this

**1** ▶ Move cursor to beginning of file.

**2** ▶ Press **CODE** **S** to start the substitute command.

# Substitute Form

TRIP REPORT SUMMARY	9/15/82
Submitted by: Tom Faneuff CCD	
Automotive sails division: District 4	
Central Region Dealer: J. Chase	
This memo recommends the redistribution of sails allotments for dealers in district 4 of the automotive sails division based on the projected	
Find	sails
Substitute	sales
Verification	Enabled
Match	Independent of Case
Direction	Forward
Substitute: Fill in form	

- 3 Type "sails" in the Find item.
- 4 Press 
- 5 Type "sales" in the Substitute item.

# Substitute Form

TRIP REPORT SUMMARY	9/15/82
Submitted by: Tom Faneuff CCD	
Automotive sails division: District 4	
Central Region Dealer: J. Chase	
This memo recommends the redistribution of sails allotments for dealers in district 4 of the automotive sails division based on the projected	
<input checked="" type="checkbox"/> Enabled <input type="checkbox"/> Disabled	
Find	sails
Substitute	sales
Verification	<input checked="" type="checkbox"/> Enabled
Match	Independent of Case
Direction	Forward
Substitute: Fill in form	

CHOICE BAND ➡

*enable verification*

*press ctrl left right*

6 Press **CTRL**   to enable verification.

# Substitute Form

TRIP REPORT SUMMARY	9/15/82
Submitted by: Tom Faneuff CCD	
Automotive sails division: District 4	
Central Region Dealer: J. Chase	
This memo recommends the redistribution of sails allotments for dealers in district 4 of the automotive sails division based on the projected	
<input checked="" type="checkbox"/> Forward <input type="checkbox"/> Backward	
Find	sails
Substitute	sales
Verification	Enabled
Match	Independent of Case
Direction	<input type="text" value="Forward"/>
Substitute: Fill in form.	

- 7 Choose "Independent of case".
- 8 Choose "Forward" direction.
- 9 CONFIRM

# Substitute Command

TRIP REPORT SUMMARY	9/15/82
Submitted by: Tom Faneuff CCD	
Automotive <b>sails</b> division: District 4	
Central Region Dealer: J. Chase	
<p>This memo recommends the redistribution of sails allotments for dealers in district 4 of the automotive sails division based on the projected sails for the first four months of 1983. (See exhibit A)</p>	
<p>My decision to recommend new sails allotments for this district is supported by the following 4</p>	
<input checked="" type="checkbox"/> Yes	No Single All
Substitute this occurrence of the text? <input type="checkbox"/> Yes	
Verify Substitution: Fill in form	



**CONFIRM all substitutions**

# Exercise

- Erase and Substitute -

- 1 Use the Erase command to erase the second to last paragraph.

3) The recently announced move of SMALL TIME RENTAL CAR CO. will significantly reduce fleet sales.

4) John Chase insulted my mother at the company picnic last September.

Please respond to my suggestion by Wednesday morning.

- 2 With the Substitute command change all occurrences of the name Chase to Hubbard.

TRIP REPORT SUMMARY

9/15/82

Submitted by: Tom Faneuff CCD

Automotive sales division: District 4

Central Region Dealer: J. Chase

Hubbard

# Commands Menu

```
TRIP REPORT SUMMARY                      9/15/82
Submitted by: Tom Faneuff  CCD
Automotive sales division: District 4

CODE-D   Duplicate
CODE-E   Erase
CODE-F   Find
CODE-J   Jump
CODE-M   Move
CODE-O   Options
CODE-Q   Quit
CODE-S   Substitute
CODE-T   Transfer
CODE-U   Usage
CODE-ESC Cancel

Commands: Select item
Version 0.4.12 of GRIDWRITE
```



Press **CODE** **?** to display commands menu.

# Options Command

TRIP REPORT SUMMARY		9/15/82
Submitted by: Tom Faneuff CCD		
Automotive sales division: District 4		
Central Region Dealer: J. Hubbard		
1-250 Window Width		
Margins:	Document Width	Window Width
	Automatic Indent	Enabled
Display:	Ruler	Disabled
	Format Characters	Disabled
Tab Stops:	Spacing	Manual Only
	First	Automatic
Cursor:	Movement by	Word
	Cursor Wrap	Enabled
Tabs for Cell-Based Files		Disabled
Options: Fill in form		

 Press   to start options command.

# Document Width Option

2 Press **CTRL** **←**

*Random Location  
- Right Margin  
- Auto Format  
- Auto Indent*

1-250 Window Width		
Margins:	Document Width	<input type="text"/>
	Automatic Indent	Enabled
Display:	Ruler	Disabled
	Format Characters	Disabled
Tab Stops:	Spacing	Manual Only
	First	Automatic
Cursor:	Movement by	Word
	Cursor Wrap	Enabled
	Tabs for Cell-Based Files	Disabled

Options: Fill in form

3 Type "80"

1-250 Window Width		
Margins:	Document Width	<input type="text" value="80"/>
	Automatic Indent	Enabled
Display:	Ruler	Disabled

# Ruler Option

TRIP REPORT SUMMARY		9/15/82
Submitted by: Tom Faneuff CCD		
Automotive sales division: District 4		
Central Region Dealer: J. Hubbard		
<b>Enabled</b> Disabled		
Margins:	Document Width	80
	Automatic Indent	Enabled
Display:	Ruler	<b>Enabled</b>
	Format Characters	Disabled
Tab Stops:	Spacing	Manual Only
	First	Automatic
Cursor:	Movement by	Word
	Cursor Wrap	Enabled
	Tabs for Cell-Based Files	Disabled
Options: Fill in form		

4 Enable ruler.

5 CONFIRM

## 80 Columns with Ruler

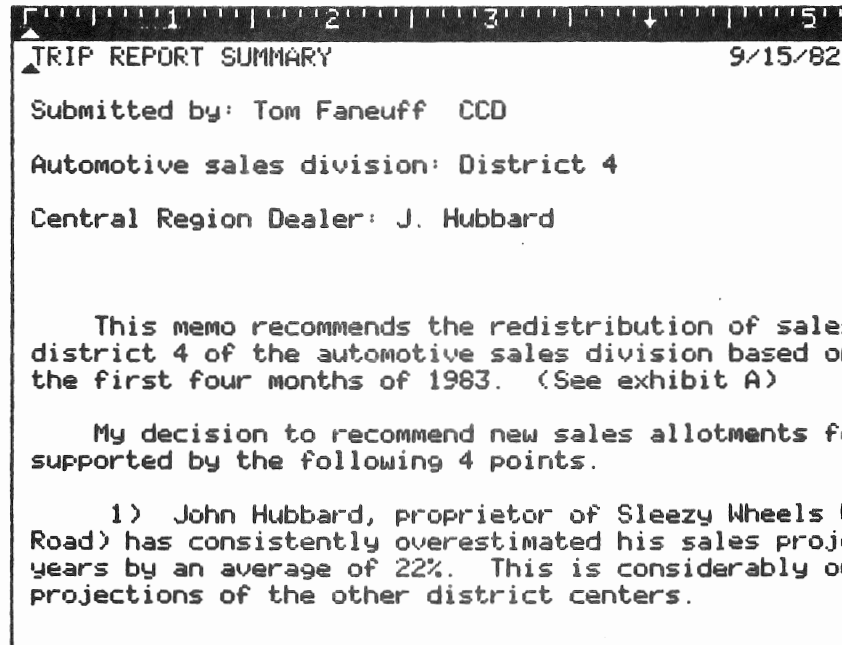

```
▲ 1 2 3 5
▲ TRIP REPORT SUMMARY 9/15/82
Submitted by: Tom Faneuff CCD
Automotive sales division: District 4
Central Region Dealer: J. Hubbard

This memo recommends the redistribution of sales allotments for dealers in
district 4 of the automotive sales division based on the projected sales for
the first four months of 1983. (See exhibit A)

My decision to recommend new sales allotments for this district is
supported by the following 4 points.

1) John Hubbard, proprietor of Sleazy Wheels Unlimited (213 E. Hummel
Road) has consistently overestimated his sales projections for the last five
years by an average of 22%. This is considerably out of line with the
projections of the other district centers.
```



Press



keys to scroll over width of file.

# Transfer Command

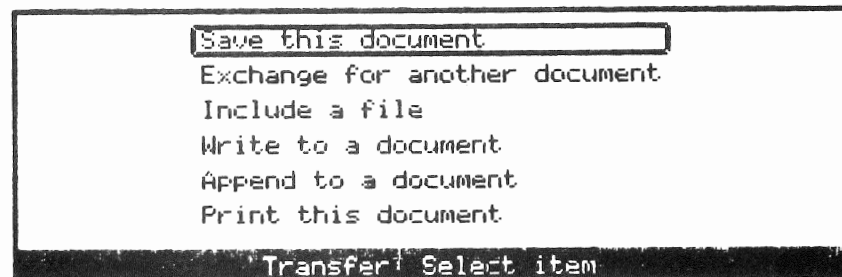

Press **CODE** **T** to start the Transfer command.

# Transfer Command

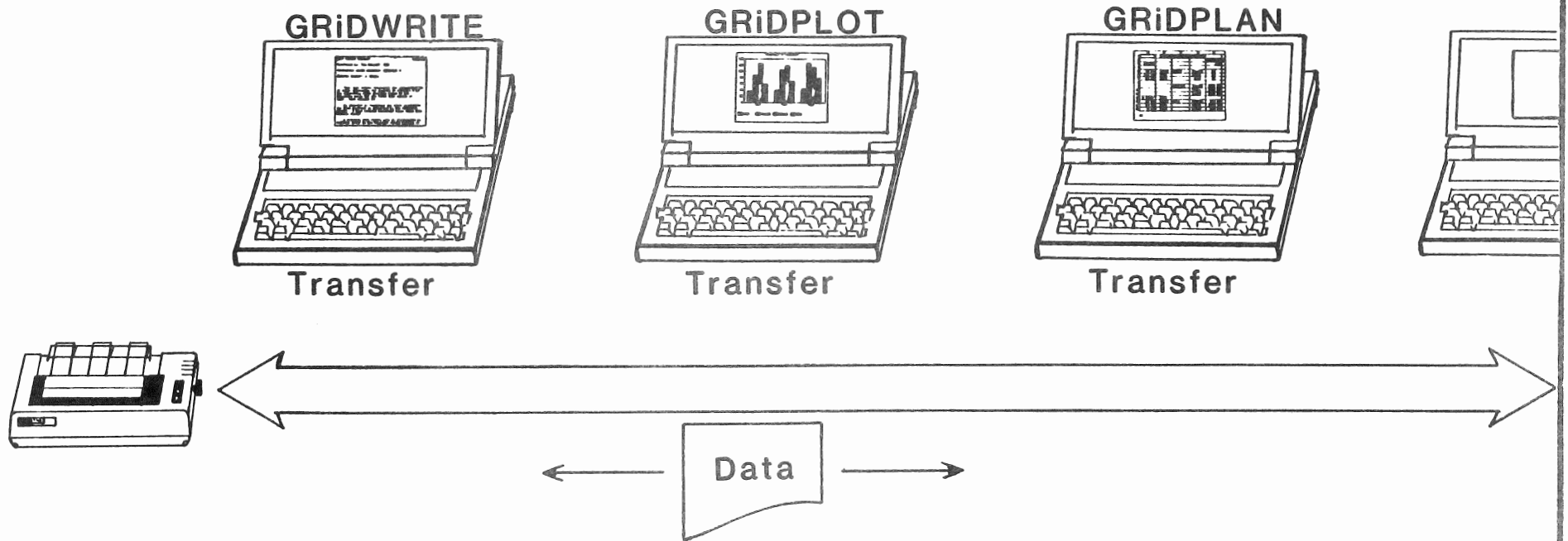

- The Transfer command allows data to be moved between every management tool.

## Returning to the Subjects Menu

```
TRIP REPORT SUMMARY          9/15/82
Submitted by: Tom Faneuff  CCD
Automotive sales division: District 4

CODE-D Duplicate
CODE-E Erase
CODE-F Find
CODE-J Jump
CODE-M Move
CODE-O Options
CODE-Q Quit
CODE-S Substitute
CODE-T Transfer
CODE-U Usage
CODE-ESC Cancel

Commands Select item
Version 0.4.12 of GRIDWRITE
```

### QUIT

- return to subjects.
- save changes

### CANCEL

- return to subjects.
- don't save changes

## Quit Command

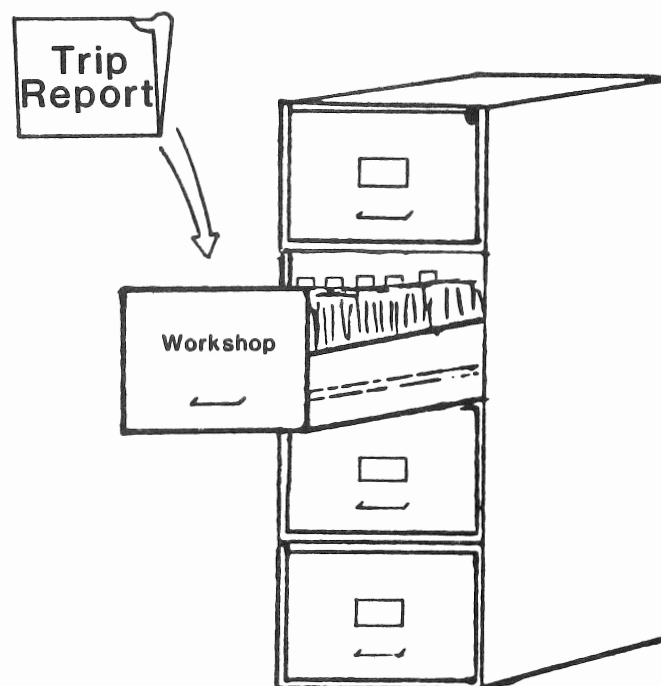

1 Press **CODE** **Q** to start the Quit command.

2 CONFIRM